

05.1



DEGRITTERS AND DEGREASERS

COMPACT PRETREATMENT



05.1

DEGRITTERS AND DEGREASERS

COMPACT PRETREATMENT

WHAT ABOUT

The DET54 COMPACT PRETREATMENT is a compact plant designed and intended for the initial treatment of urban, industrial and waste water. The objective of this pretreatment is to eliminate thick solids (sifting - sieving), sands (degritting) and fats (degreasing) from input flows of up to 500 m³/hr.

The compact pretreatment operates on the basis of the waste water reaching the unit through the Spiral Sieve area. This separates the inbound solids, removing and compacting them, sending them to the discharge hole where, via a ramp, they are deposited in the appropriate container.

Sand settles at the bottom of the compact plant enclosure, where two Spiral Conveyors collect it and move it to the surface where it is discharged down a ramp into another container. The fats are homogenised by an air injection system, focused on the area intended for their removal, where a surface scraper sweeps everything towards the collection hopper.

It is very easy to install the compact pretreatment. It is far superior to any conventional civil works installation in small-town treatment plants. As it is a single unit, the compact pretreatment only needs to be anchored to the surface of the enclosure and connected to the inlet and outlet pipes.

Among the main advantages of compact pretreatment, the following are noteworthy: operational safety; easy installation in small spaces; no odours or spatter; low running costs; separate extraction of sands, fats and thick solids; and low maintenance and operational costs.

It is manufactured in various standard sizes - depending on the flows being treated - using modular sections that make transportation easy.



05.1

DEGRITTERS AND DEGREASERS

COMPACT PRETREATMENT

CONTAINER BODY

Made wholly of AISI 304 or 316 single unit stainless steel, this is where all the screening, degritting and degreasing units are embedded. It has a fluid inlet and outlet for the flow chosen, legs which can be adjusted to the floor level and upper sealing caps.

FINE SIEVE

Comprising a drive unit, filtering grille, a helix system with cleaning brush with an extendible screw lifter and the compacting and draining area.

SCREW EXTRACTOR FOR SAND

Coreless auger screws whose turning motion brushes against a wear-resistant polyethylene cradle. One of these located at the bottom of the tank washes the sands towards the trough of another screw which is at an angle that raises the sand to the discharge spout.

FAT AND FLOATING PARTICLE SEPARATOR AND REMOVER

Based on an air injector system, using a collector located in the lower section of the tank. This process is completed with a separating plate with special openings and a motorised pulley and cable system which moves the surface scraper along one side and across the whole of the enclosure, thus discharging the fats into a hopper at one of the ends.

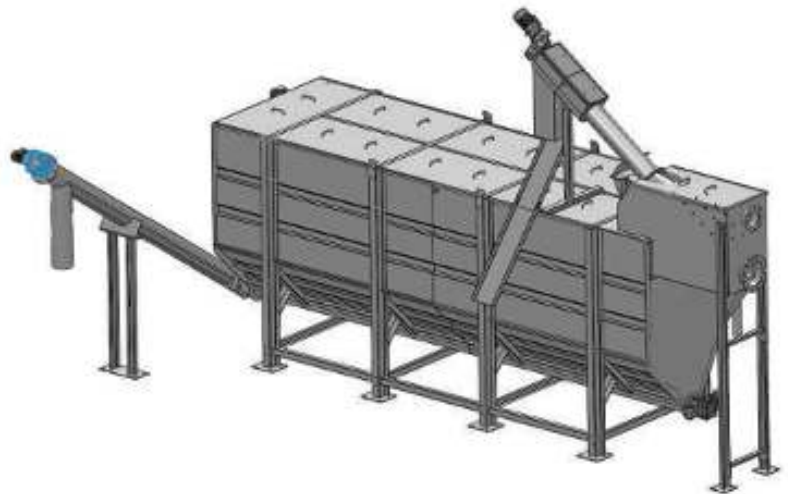

DESIGN PARAMETERS

Flow

Retention time

Manufacturing material

