

# 06.2



## AERATORS

# AERATION TURBINE



## AERATORS

# AERATION TURBINE

### WHAT ABOUT

The DET05 AERATION TURBINE is suitable for waste water treatment and its purpose is to provide and spread oxygen through the body of liquid, in addition to stirring the sludge and preventing sedimentation at the bottom of the tank.

In the aeration turbine the water is aspirated vertically by the runner from the bottom of the tank and ejected through the vanes at a height similar to that of the water level. Oxygen is added in the choppy area on the water surface.

The circulation capacity of this type of aerator means this oxygen is dispersed homogeneously throughout all the water in the tank.

The aeration turbine can be mounted on a concrete walkway or steel profiles as long as these are sufficiently rigid to absorb harmful vibrations produced while it is operating and which might damage it.

Nominal oxygen provision is expressed in Kg O<sub>2</sub> / kWh consumed. As a general rule, 1.8 to 2 Kg of O<sub>2</sub> can be used per kWh for an oxygen demand (DBO<sub>5</sub>) of:

- Small Plants: 2 Kg O<sub>2</sub> / Kg DBO<sub>5</sub>
- Large Plants: 1.4 - 1.6 Kg O<sub>2</sub> / Kg DBO<sub>5</sub>

FACTORS DIRECTLY LINKED TO THE DET05 AERATION TURBINE EFFECTIVELY PROVIDING OXYGEN:

- Immersion.
- Rotation speed.
- Operational time.
- Waste water quality.
- Tank size and the width/height ratio.
- Hydraulic radius.
- Drop in performance due to partial obstruction of the runner.
- Salinity and temperature.

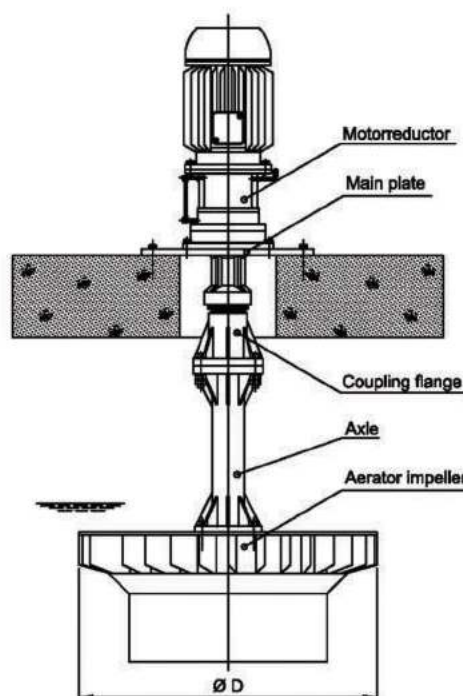

SELECTION TABLE AND OXIGEN CONTRIBUTION

Ref.	POWER	ØD	Kg. O <sub>2</sub> /hour			Max volume of agitation m <sup>3</sup>
			*1,6	**1,8	***2,0	
DET05-30	3	0,825	3,6	4,05	4,5	90
DET05-40	4		4,8	5,4	6	120
DET05-55	5,5		6,6	7,42	8,25	165
DET05-75	7,5	0,915	9	10,1	11,25	225
DET05-100	10		12	13,5	15	300
DET05-150	15	1,000	18	20,2	22,5	450
DET05-200	20	1,225	24	27	30	600
DET05-250	25	1,375	30	33,75	37,5	750
DET05-300	30	1,575	36	40,5	45	900
DET05-400	40	1,825	48	54	60	1.200
DET05-500	50	1,975	60	67,5	75	1.500
DET05-600	60	2,300	72	81	90	1.800
DET05-750	75		90	101,2	112,5	2.250

\* For a 1,6 Kg. O<sub>2</sub>/Kwh contribution

\*\* For a 1,8 Kg. O<sub>2</sub>/Kwh contribution

\*\*\* For a 2,0 Kg. O<sub>2</sub>/Kwh contribution

Dimensions in meters

## AERATORS

# AERATION TURBINE

### RUNNER

Made from plate whose thickness varies according to the size; it consists of an upper shield flange-connected with the shaft, vanes and a lower diffuser. The vanes can move clockwise or anti-clockwise. This allows the aeration turbine to work leftwards or rightwards depending on the client's needs.

### DRIVE UNIT

This consists of a geared motor unit, positioned and flange-connected to the base plate. The power and reduction vary according to the model built.

### SHAFT

This comprises a circular cross-section pipe whose thickness varies per the model. It is strengthened using brackets and has a flange at either end.

### BASE PLATE FOR ANCHORAGE

Base plate for anchorage: Plate on which the drive unit is supported; comprised of tensing rods at the ends which allow the height of the unit to be adjusted slightly.

